

Drawings for Manufacturing of Shock Absorber Test Rig

Sr. No.	Drawing No.	Drawing Name
1	CIRT/SDL/SATR/001	SHOCK ABSORBER TEST RIG ASSY.
2	CIRT/SDL/SATR/003	MECHANISM BASE
3	CIRT/SDL/SATR/004	SUPPORT PILLER
4	CIRT/SDL/SATR/005	GEAR BOX MOUNTING
5	CIRT/SDL/SATR/006	SA MOUNTING FIXTURE
6	CIRT/SDL/SATR/007	ECCENTRIC PLATE
7	CIRT/SDL/SATR/008	INDEXING PLATE
8	CIRT/SDL/SATR/009	JACK SUPPORT
9	CIRT/SDL/SATR/010	CONNECTING ROD
10	CIRT/SDL/SATR/011	CLAMPING BRACKET
11	CIRT/SDL/SATR/012	SHAFT 1
12	CIRT/SDL/SATR/013	CONNECTING ELBOW
13	CIRT/SDL/SATR/014	ROPE ROLLER HUB
14	CIRT/SDL/SATR/015	ROPE ROLLER COVER
15	CIRT/SDL/SATR/016	PULLEY CLAMP
16	CIRT/SDL/SATR/017	20mm BUSH
17	CIRT/SDL/SATR/018	20mm PIN
18	CIRT/SDL/SATR/019	WIRE CLAMP
19	CIRT/SDL/SATR/020	BEARING SEAT
20	CIRT/SDL/SATR/021	BEARING HUB
21	CIRT/SDL/SATR/022	WATER TUB

CIRT/SDL/SATR/001

ALL DIM. ARE IN mm

ITEM NO.	PART	DESCRIPTION	QTY.
1	Mechanism Base	CIRT/SDL/SATR/003	1
2	Support Pillar	CIRT/SDL/SATR/004	3
3	Gear Box Mounting Plate	CIRT/SDL/SATR/005	1
4	IS 2269 - M16 x 60-N	M16 X 60 SOCKET HEAD BOLT	8
5	IS 2269 - M10 x 60-N	M10 X 60 SOCKET HEAD BOLT	14
6	IS 2269 - M10 x 20-N	M10 X 20 SOCKET HEAD BOLT	8
7	IS 15581 - M10-N	M10 NUT	14
8	IS 15581 - M16-N	M16 NUT	8
9	SA Mounting Fixture	CIRT/SDL/SATR/006	2
10	Eccentric Plate	CIRT/SDL/SATR/007	1
11	Indexing Plate	CIRT/SDL/SATR/008	1
12	Jack Support	CIRT/SDL/SATR/009	1
13	M10 x 1.5 x 40 Hex ScH Bolt	M10X40 SOCKET HEAD BOLT	32
14	IS 1364-4 - M12-N	M12 NUT	14
15	6005-2RSH	SKF BEARING 6005 2RSH	4
16	2 mm Washer	OD28xD16xH2	6
17	Connecting Rod	CIRT/SDL/SATR/010	1
18	bush 2	OD30xD14xH15	4
19	Clamping Bracket	CIRT/SDL/SATR/011	8
20	Shaft 1	CIRT/SDL/SATR/012	3
21	Connecting Elbow	CIRT/SDL/SATR/013	1
22	Rope Roller hub	CIRT/SDL/SATR/014	2
23	Rope Roller cover	CIRT/SDL/SATR/015	2
24	pulley clamp	CIRT/SDL/SATR/016	2
25	wire rope	MULTI STRANDED DIA 10 ROPE	1
26	20mm bush	CIRT/SDL/SATR/017	4
27	20mm pin	CIRT/SDL/SATR/018	2
28	wire clamp	CIRT/SDL/SATR/019	1
29	M10 x 1.5, Hex Flange Nut	M10 FLANGE NUT	20
30	Bearing Seat	CIRT/SDL/SATR/020	2
31	Bearing Hub	CIRT/SDL/SATR/021	2
32	water seal rubber	USE MATCHING	1
33	water tub	CIRT/SDL/SATR/022	1

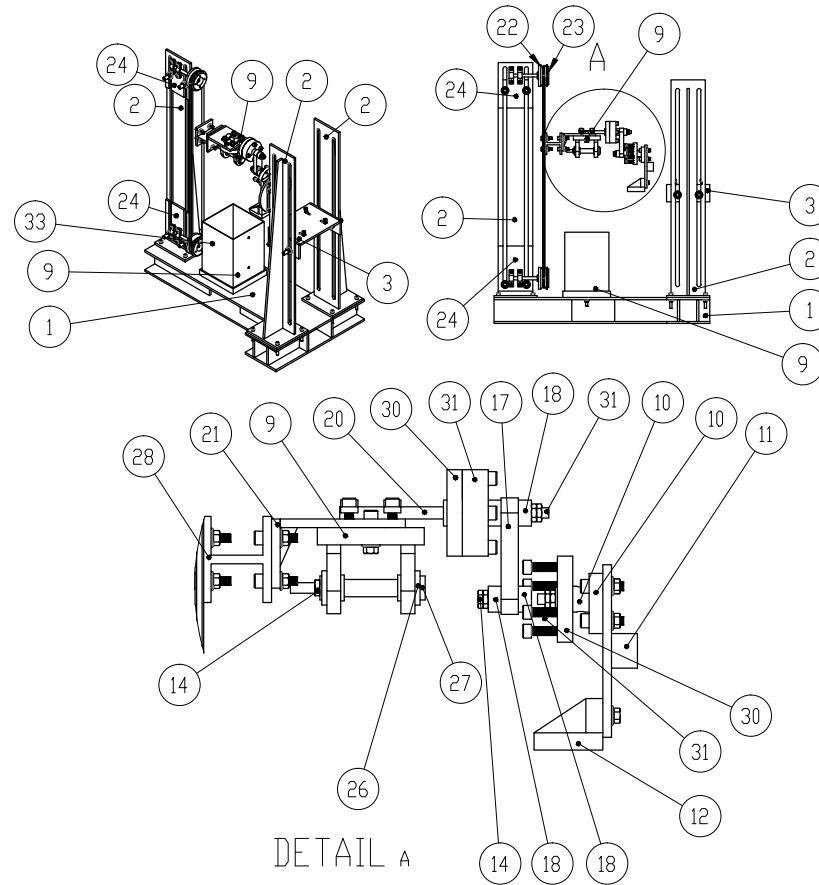

DETAIL A

SCALE 1 : 5

S.NO.	MATERIAL	QTY	WT.(Kg)	DETAILS	SIGN & DATE
Central Institute Of Road Transport					
THIS DRAWING IS SOLE PROPERTY OF CIRT. IT SHOULD NOT BE COPIED OR COMMUNICATED TO ANY PERSON WITHOUT THE WRITTEN APPROVAL OF THE PROPRIETORS					
DRAWN	Sanket S. D.	ALL DIMENSIONS ARE IN mm		DRG. NOT TO BE SCALED	
CHECKED	Mhetre T. R.	UNCLASSIFIED IF NOT MENTIONED		ALL SHARP EDGES TO BE ROUNDED OFF	
PASSED		SCALE	1:1	PERTAINS TO -	
APPROVED		DATE	18/08/16		
TITLE Shock Absorber Test rig Assy (FOR S.D.L)				CIRT.DRG.NO. CIRT/SDL/SATR/001	

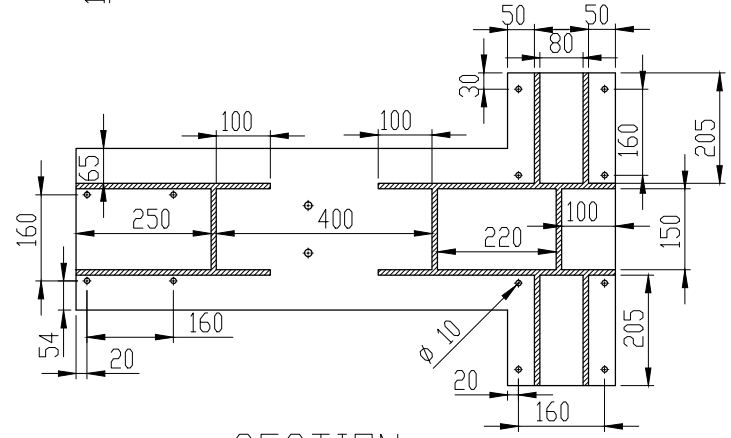
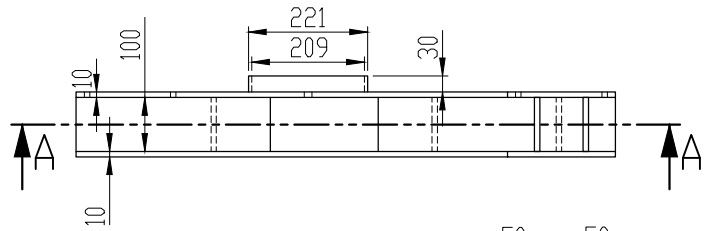
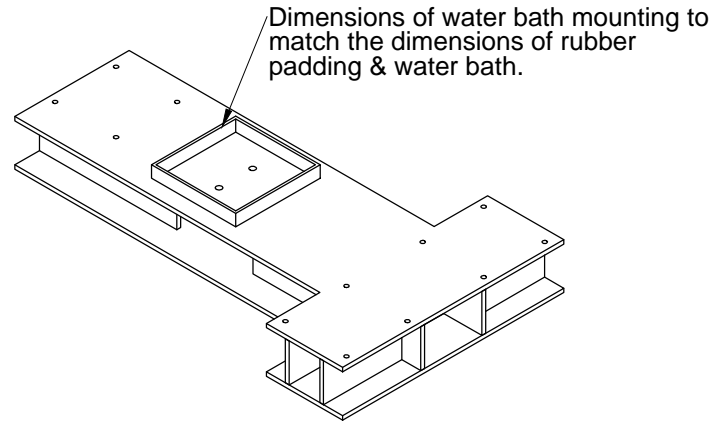
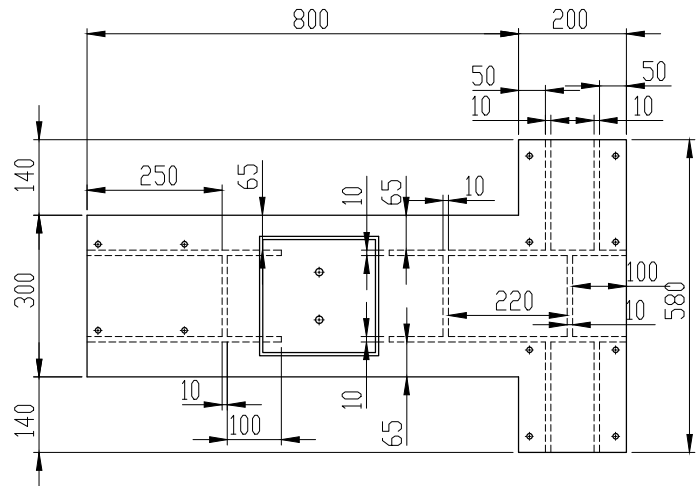

SECTION A-A

En-8		DETAILS		SIGN & DATE
S.NO.	MATERIAL	QTY	WT.(Kg)	REVISION No.00
Central Institute Of Road Transport				
THIS DRAWING IS SOLE PROPERTY OF CIRT. IT SHOULD NOT BE COPIED OR COMMUNICATED TO ANY PERSON WITHOUT THE WRITTEN APPROVAL OF THE PROPRIETORS				
DRAWN	Sanket S. D.	ALL DIMENSIONS ARE IN mm		DRG. NOT TO BE SCALED
CHECKED	Mhetre T. R.	UNCLASSIFIED IF NOT MENTIONED	ALL SHARP EDGES TO BE ROUNDED OFF	
PASSED		SCALE 1:1	PERTAINS TO -	
APPROVED		DATE 18/08/16		
TITLE			CIRT.DRG.NO.	
Mechanism Base (FOR S.D.L/SATR)			CIRT/SDL/SATR/003	

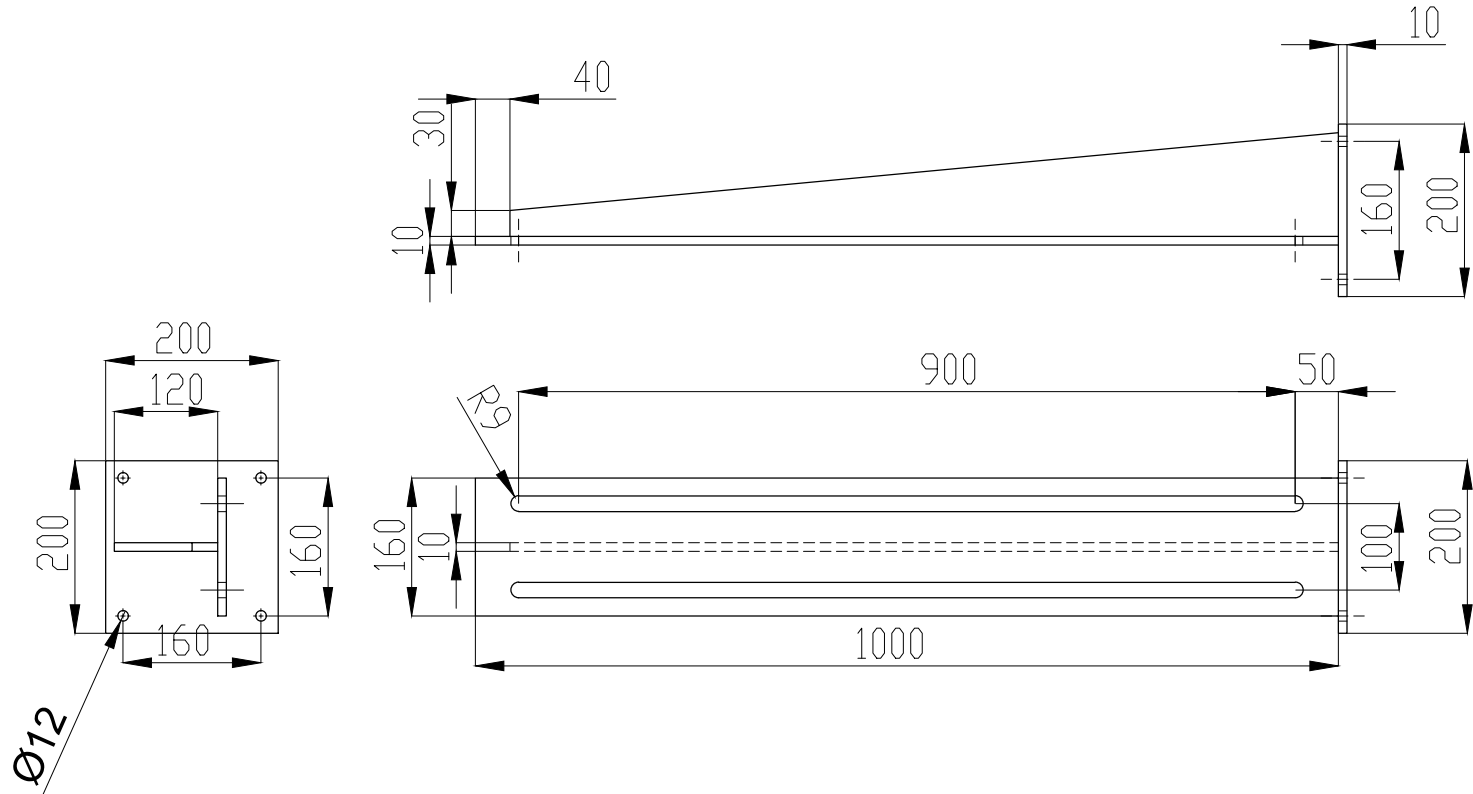

En-8		DETAILS		SIGN & DATE
S.NO.	MATERIAL	QTY	WT.(Kg)	REVISION No.00
Central Institute Of Road Transport				
THIS DRAWING IS SOLE PROPERTY OF CIRT. IT SHOULD NOT BE COPIED OR COMMUNICATED TO ANY PERSON WITHOUT THE WRITTEN APPROVAL OF THE PROPRIETORS				
DRAWN	Sanket S. D.	ALL DIMENSIONS ARE IN mm		DRG. NOT TO BE SCALED
CHECKED	Mhetre T. R.	UNCLASSIFIED IF NOT MENTIONED		ALL SHARP EDGES TO BE ROUNDED OFF
PASSED		SCALE	1:1	PERTAINS TO -
APPROVED		DATE	18/08/16	
TITLE				CIRT.DRG.NO.
Support Pillar (FOR S.D.L/ SATR)				CIRT/SDL/SATR/004

TOLERANCE UNLESS OTHERWISE SPECIFIED TO BE AS PER IS: 2875

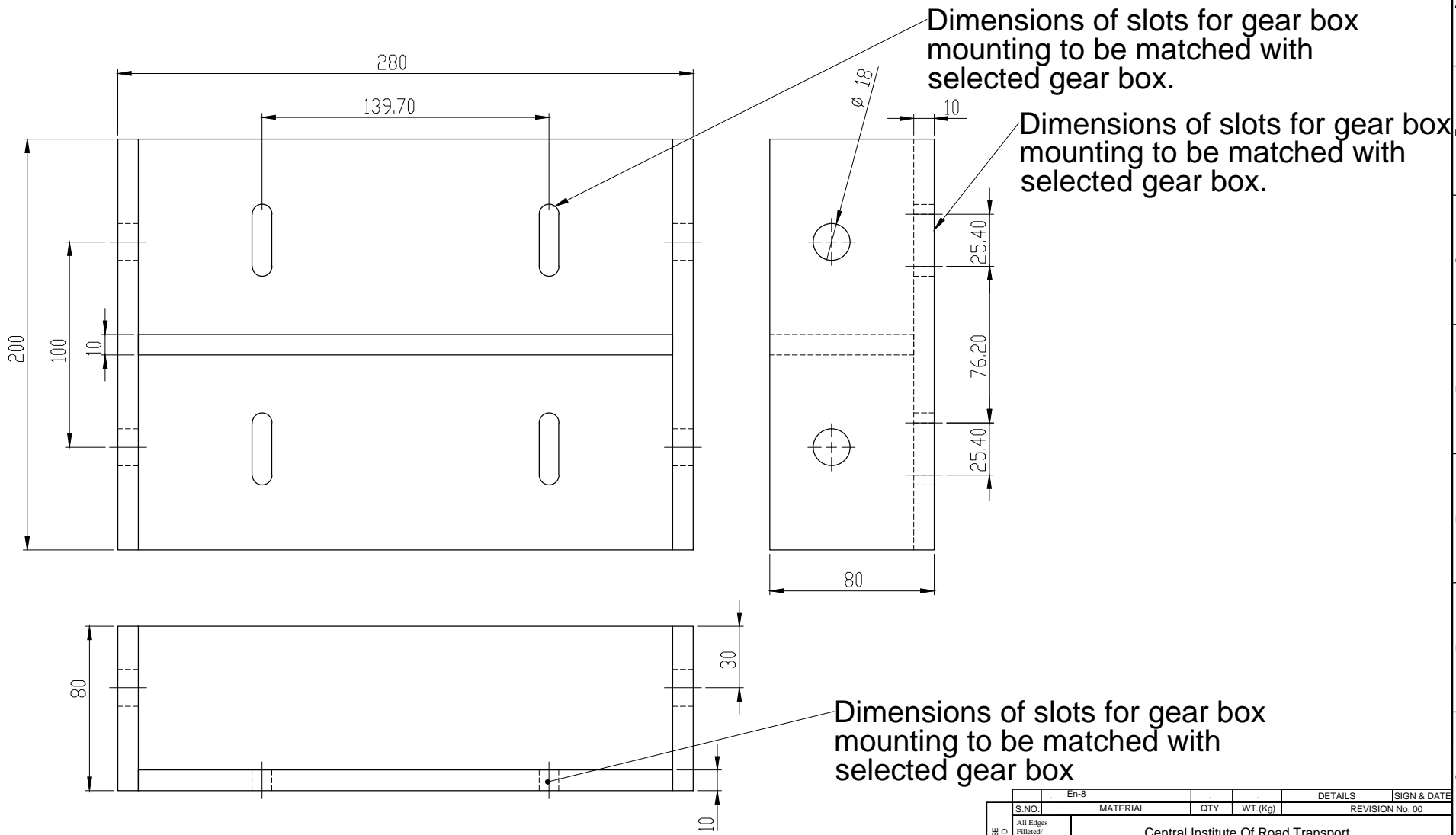

S.NO.		En-8		DETAILS		SIGN & DATE	
MATERIAL		QTY		WT.(Kg)		REVISION No.00	
Central Institute Of Road Transport							
THIS DRAWING IS SOLE PROPERTY OF CIRT. IT SHOULD NOT BE COPIED OR COMMUNICATED TO ANY PERSON WITHOUT THE WRITTEN APPROVAL OF THE PROPRIETORS							
DRAWN	Sanket S. D.	ALL DIMENSIONS ARE IN mm			DRG. NOT TO BE SCALED		
CHECKED	Mhetre T. R.	UNCLASSIFIED IF NOT MENTIONED			ALL SHARP EDGES TO BE ROUNDED OFF		
PASSED		SCALE	1:1		PERTAINS TO -		
APPROVED		DATE	18/08/16				
TITLE						CIRT.DRG.NO.	
Gear Box Mounting (FOR S.D./SATR)						CIRT/SDL/SATR/005	

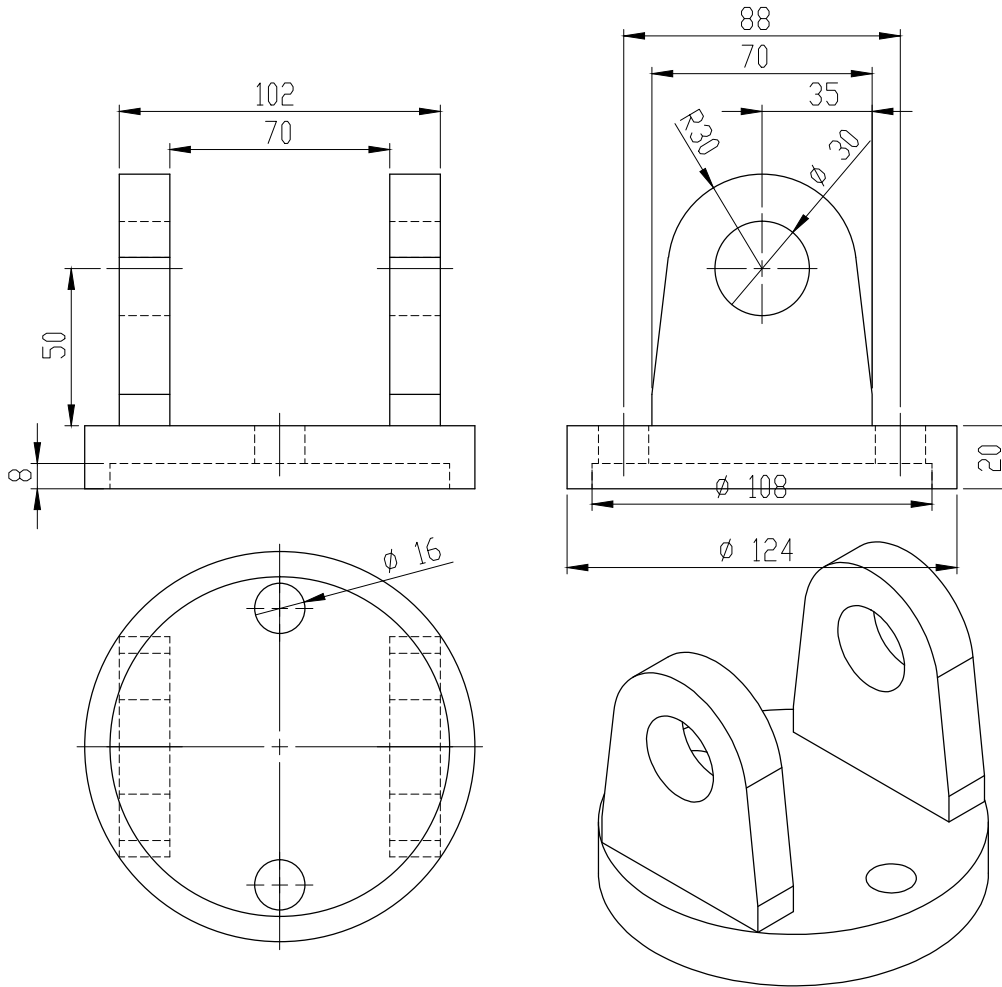

S.NO.		En-8		DETAILS		SIGN & DATE	
MATERIAL		QTY		WT.(Kg)		REVISION No.00	
Central Institute Of Road Transport							
THIS DRAWING IS SOLE PROPERTY OF CIRT. IT SHOULD NOT BE COPIED OR COMMUNICATED TO ANY PERSON WITHOUT THE WRITTEN APPROVAL OF THE PROPRIETORS							
DRAWN	Sanket S. D.	ALL DIMENSIONS ARE IN mm		DRG. NOT TO BE SCALED			
CHECKED	Mhetre T. R.	UNCLASSIFIED IF NOT MENTIONED		ALL SHARP EDGES TO BE ROUNDED OFF			
PASSED		SCALE	1:1	PERTAINS TO -			
APPROVED		DATE	18/08/16				
TITLE						CIRT.DRG.NO.	
SA Mounting Fixture (FOR S.D.L / SATR)						CIRT/SDL/SATR/006	

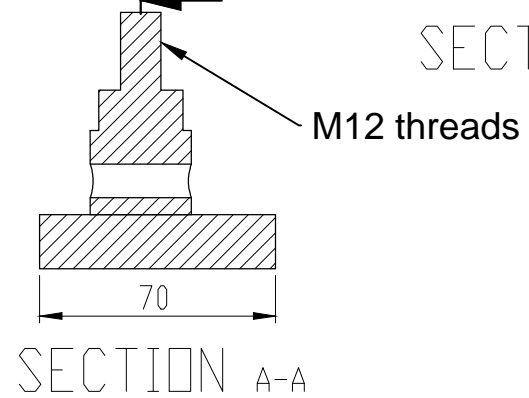
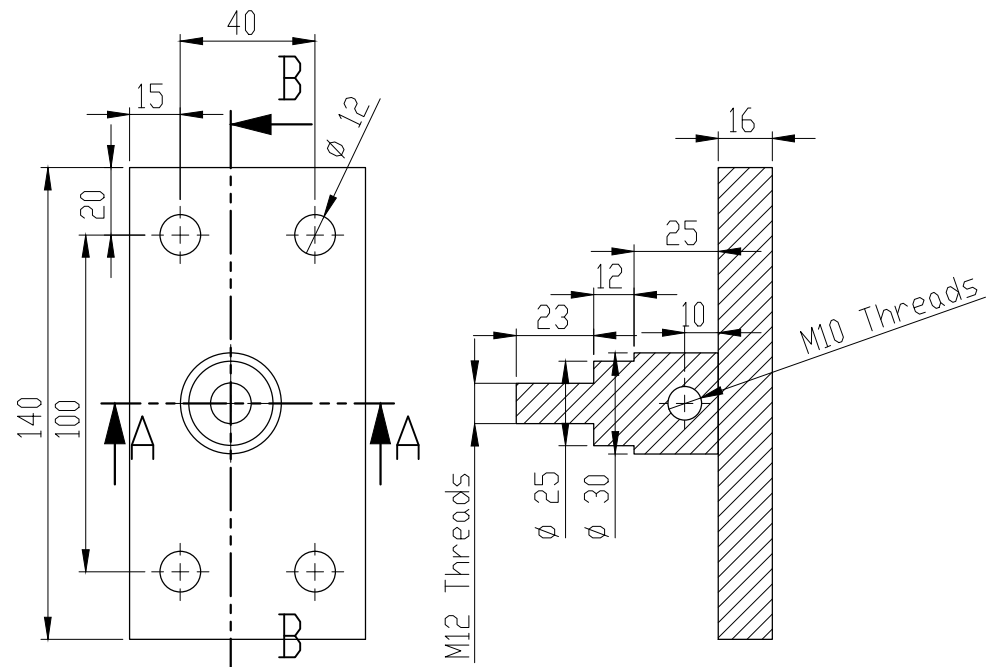

En-8		DETAILS		SIGN & DATE
S.NO.	MATERIAL	QTY	WT.(Kg)	REVISION No.00
Central Institute Of Road Transport THIS DRAWING IS SOLE PROPERTY OF CIRT. IT SHOULD NOT BE COPIED OR COMMUNICATED TO ANY PERSON WITHOUT THE WRITTEN APPROVAL OF THE PROPRIETORS				
DRAWN	Sanket S. D.	ALL DIMENSIONS ARE IN mm		DRG. NOT TO BE SCALED
CHECKED	Mhetre T. R.	UNCLASSIFIED IF NOT MENTIONED		ALL SHARP EDGES TO BE ROUNDED OFF
PASSED		SCALE	1:1	PERTAINS TO -
APPROVED		DATE	18/08/16	
TITLE			CIRT.DRG.NO.	
Eccentric Plate (FOR S.D./SATR)			CIRT/SDL/SATR/007	

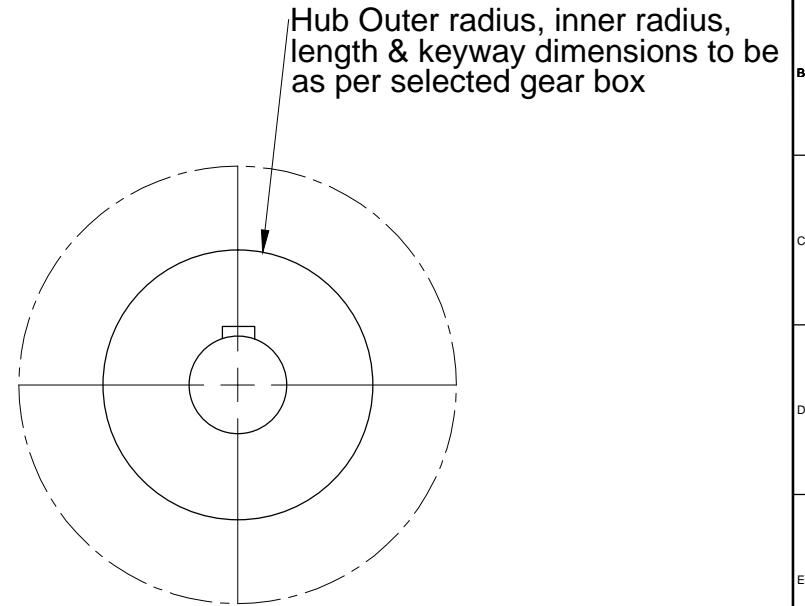
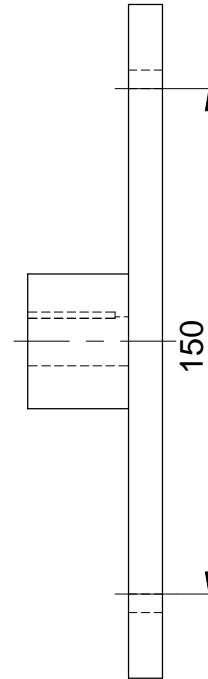
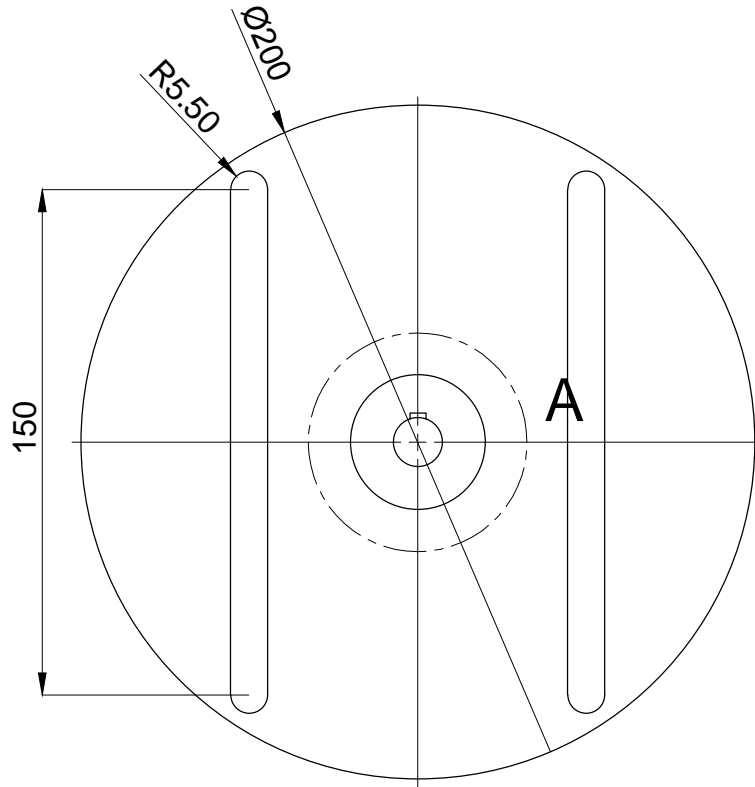

DETAIL A

SCALE 1 : 1

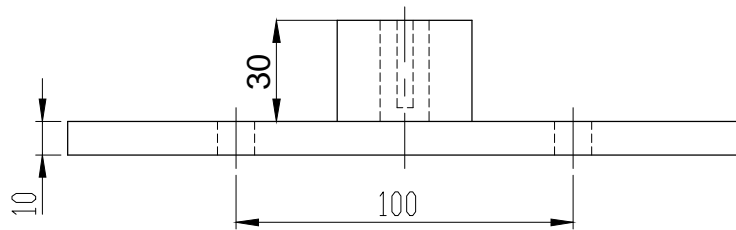

En-8		DETAILS		SIGN & DATE
S.NO.	MATERIAL	QTY	WT.(Kg)	REVISION No.00
Central Institute Of Road Transport				
THIS DRAWING IS SOLE PROPERTY OF CIRT. IT SHOULD NOT BE COPIED OR COMMUNICATED TO ANY PERSON WITHOUT THE WRITTEN APPROVAL OF THE PROPRIETORS				
DRAWN	Sanket S. D.	ALL DIMENSIONS ARE IN mm	DRG. NOT TO BE SCALED	
CHECKED	Mhetre T. R.	UNCLASSIFIED IF NOT MENTIONED	ALL SHARP EDGES TO BE ROUNDED OFF	
PASSED		SCALE 1:1	PERTAINS TO -	
APPROVED		DATE 18/08/16		
TOLERANCE UNLESS OTHERWISE SPECIFIED TO BE AS PER IS: 2875-1987			CIRT .DRG.NO. CIRT/SDL/SATR/008	
TITLE Indexing Plate (FOR S.D./SATR)				

CIRT/SDL/SATR/009

ALL DIM. ARE IN mm

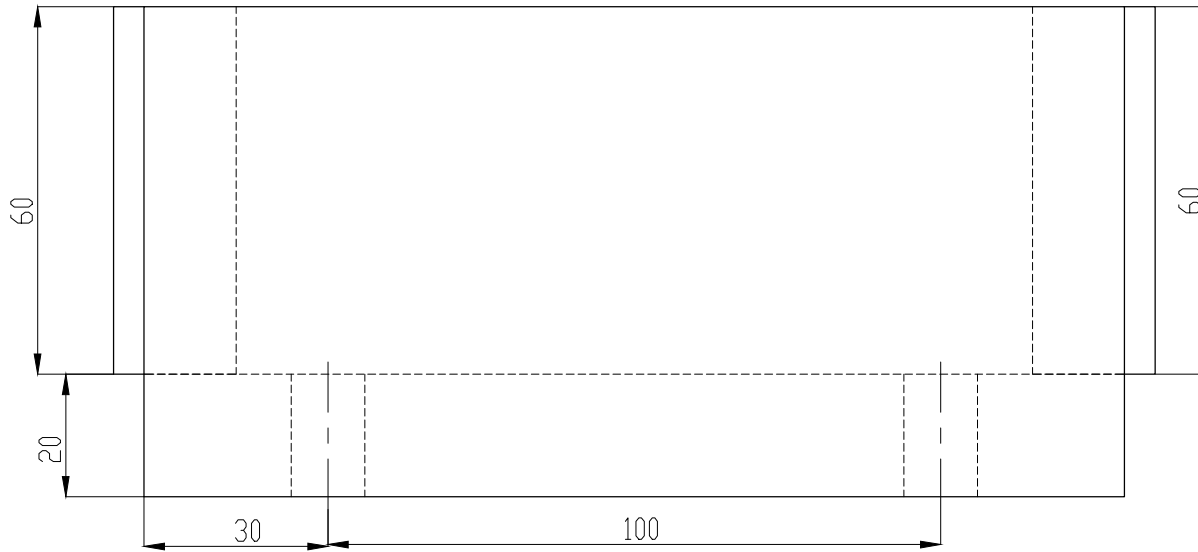
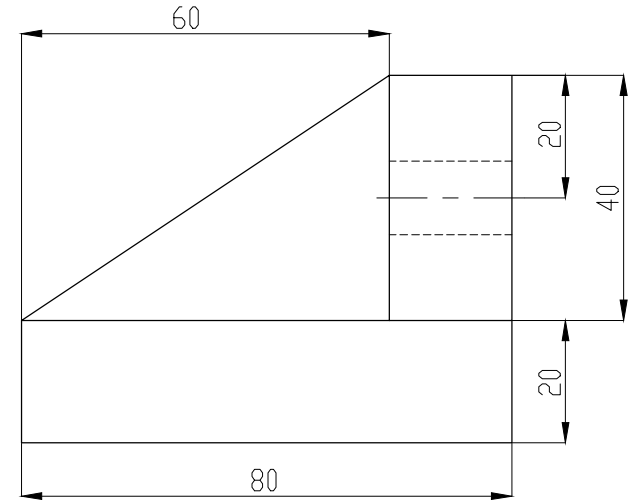
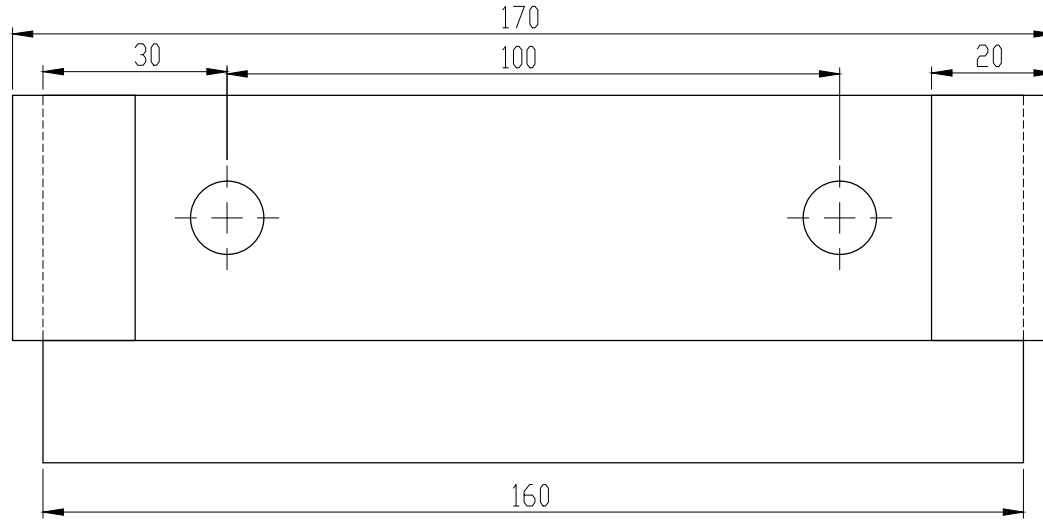

En-8		DETAILS		SIGN & DATE
S.NO.	MATERIAL	QTY	WT.(Kg)	REVISION No.00
Central Institute Of Road Transport				
THIS DRAWING IS SOLE PROPERTY OF CIRT. IT SHOULD NOT BE COPIED OR COMMUNICATED TO ANY PERSON WITHOUT THE WRITTEN APPROVAL OF THE PROPRIETORS				
DRAWN	Sanket S. D.	ALL DIMENSIONS ARE IN mm		DRG. NOT TO BE SCALED
CHECKED	Mhetre T. R.	UNCLASSIFIED IF NOT MENTIONED	ALL SHARP EDGES TO BE ROUNDED OFF	
PASSED		SCALE	1:1	PERTAINS TO -
APPROVED		DATE	18/08/16	
TOLERANCE UNLESS OTHERWISE SPECIFIED TO BE ±0.15mm			CIRT_DRG.NO.	
TITLE			CIRT/SDL/SATR/009	
Jack Support (FOR S.D./SATR)				

CIRT/SDL/SATR/010

ALL DIM. ARE IN mm

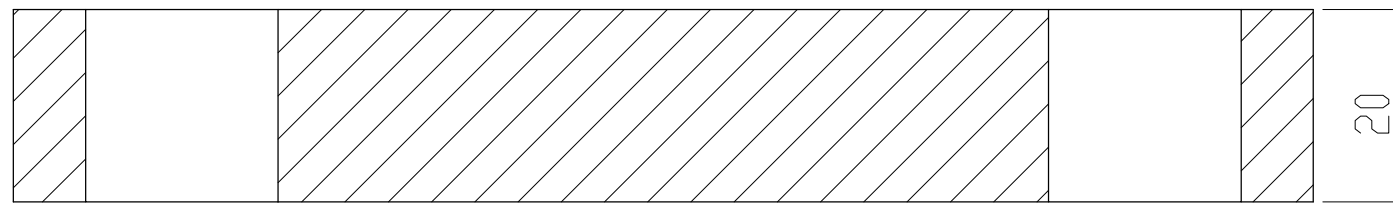
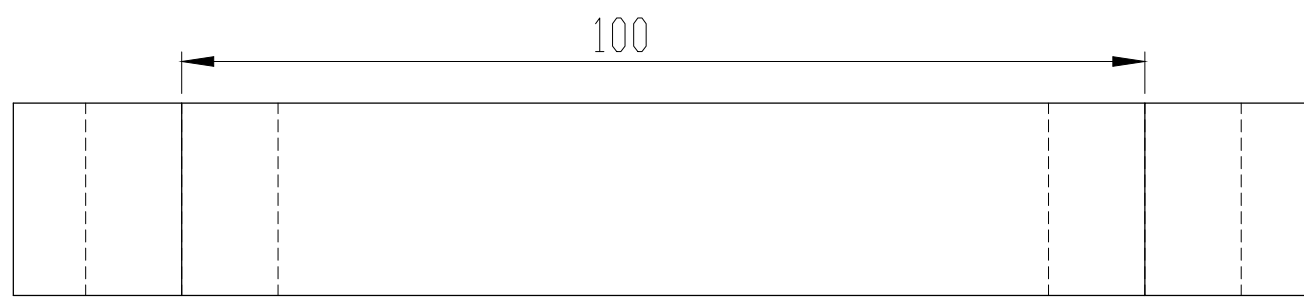
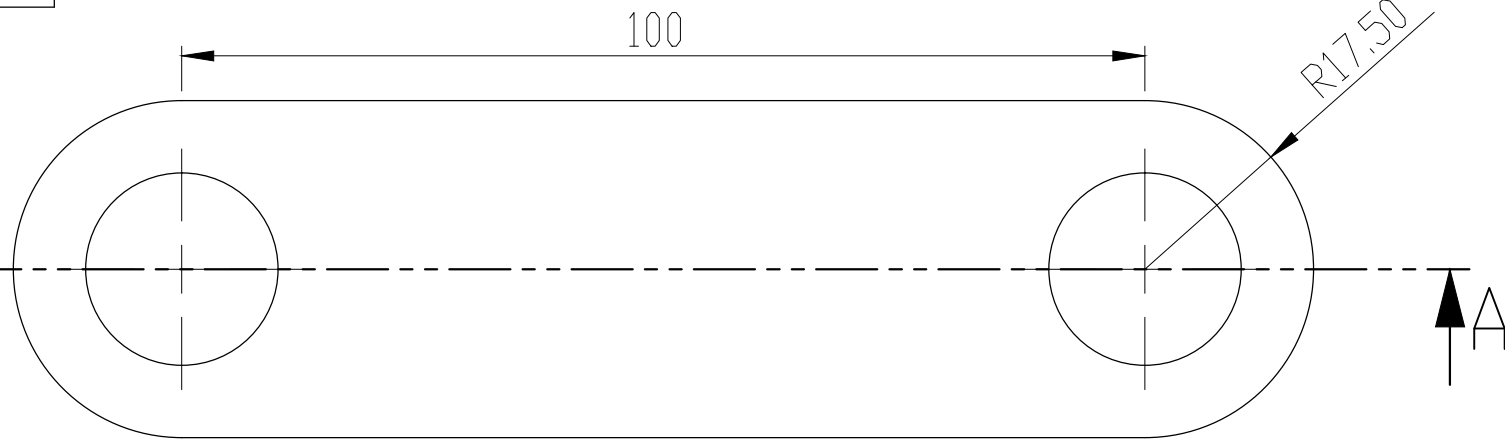

SECTION A-A

En-8		DETAILS		SIGN & DATE	
S.NO.	MATERIAL	QTY	WT.(Kg)	REVISION No.00	
All Edges Filletted/Rounded. No Sharp corners Central Institute Of Road Transport THIS DRAWING IS SOLE PROPERTY OF CIRT. IT SHOULD NOT BE COPIED OR COMMUNICATED TO ANY PERSON WITHOUT THE WRITTEN APPROVAL OF THE PROPRIETORS					
DRAWN	Sanket S. D.	ALL DIMENSIONS ARE IN mm		DRG. NOT TO BE SCALED	
CHECKED	Mhetre T. R.	UNCLASSIFIED IF NOT MENTIONED		ALL SHARP EDGES TO BE ROUNDED OFF	
PASSED		SCALE	1:1	PERTAINS TO -	
APPROVED		DATE	18/08/16		
TITLE				CIRT .DRG.NO.	
Connecting Rod (FOR S.D./SATR)				CIRT/SDL/SATR/010	

CIRT/SDL/SATR/011

ALL DIM. ARE IN mm

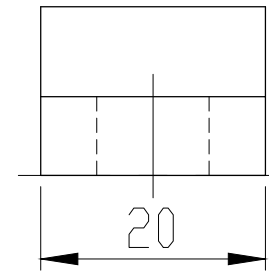
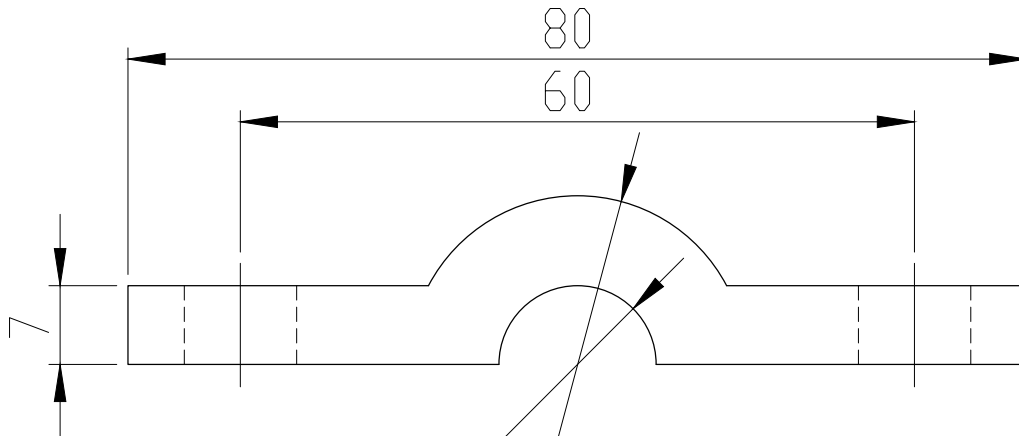
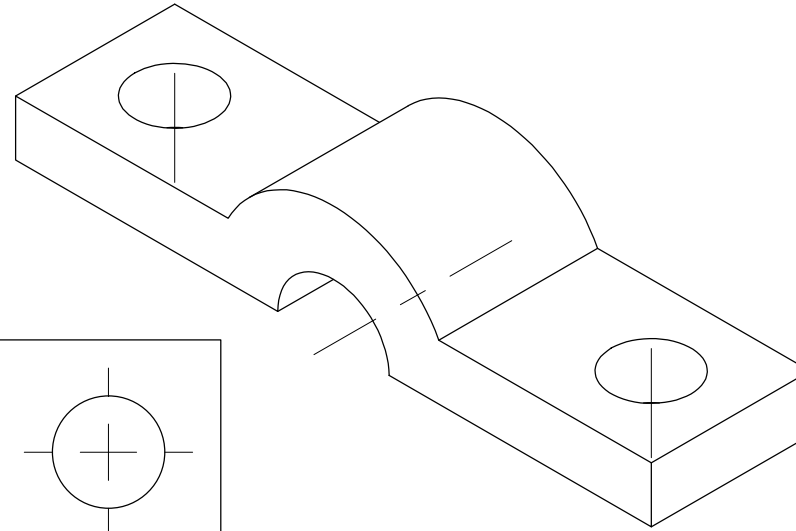
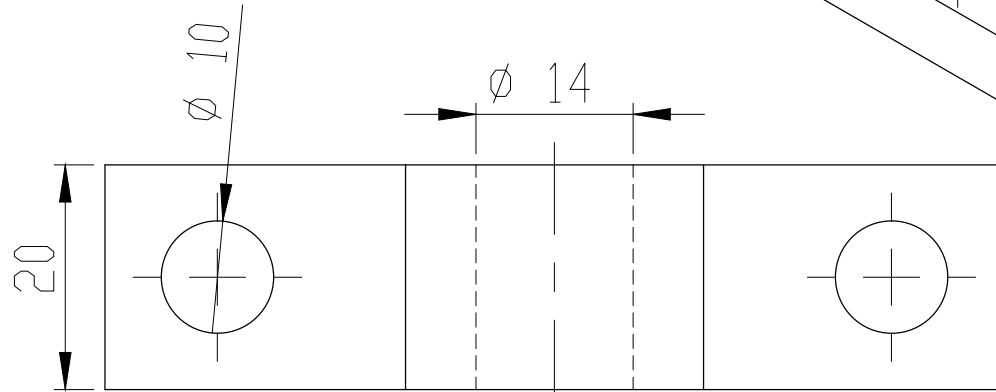

R7
R15

En-8		DETAILS		SIGN & DATE
S.NO.	MATERIAL	QTY	WT.(Kg)	REVISION No.00
All Edges Filleted/Rounded.No Sharp corners				
Central Institute Of Road Transport				
THIS DRAWING IS SOLE PROPERTY OF CIRT. IT SHOULD NOT BE COPIED OR COMMUNICATED TO ANY PERSON WITHOUT THE WRITTEN APPROVAL OF THE PROPRIETORS				
DRAWN	Sanket S. D.	ALL DIMENSIONS ARE IN mm	DRG. NOT TO BE SCALED	
CHECKED	Mhetre T. R.	UNCLASSIFIED IF NOT MENTIONED	ALL SHARP EDGES TO BE ROUNDED OFF	
PASSED		SCALE 1:1	PERTAINS TO -	
APPROVED		DATE 18/08/16		
TITLE			CIRT.DRG.NO.	
Clamping Braket (FOR S.D./SATR)			CIRT/SDL/SATR/011	

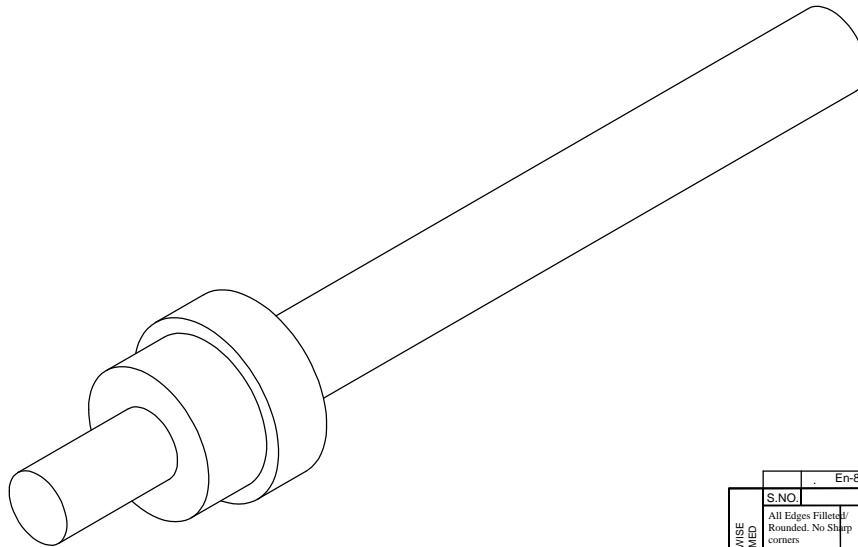
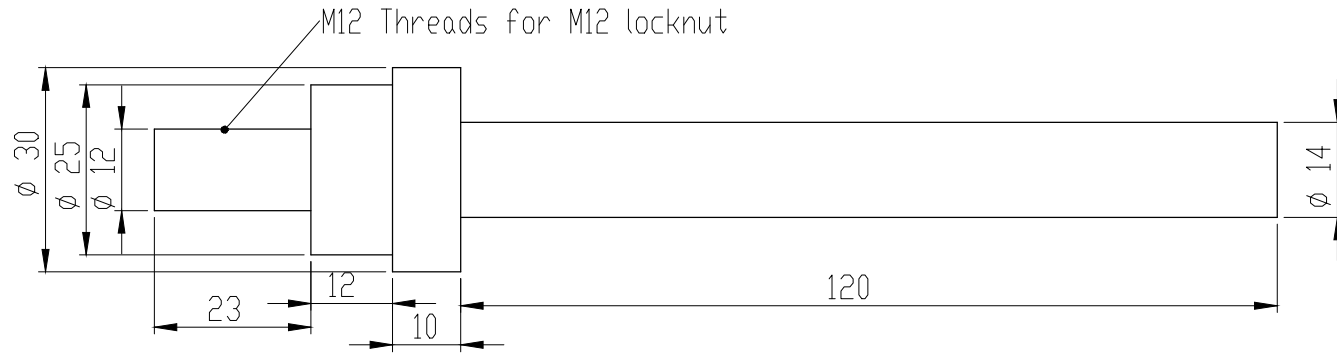

TOLERANCE UNLESS OTHERWISE SPECIFIED TO IS:2102. GD&M	S.NO. En-8		DETAILS		SIGN & DATE
	MATERIAL		QTY	WT.(Kg)	REVISION No. 00
	All Edges Filleted/ Rounded. No Sharp corners				
	Central Institute Of Road Transport				
	THIS DRAWING IS SOLE PROPERTY OF CIRT. IT SHOULD NOT BE COPIED OR COMMUNICATED TO ANY PERSON WITHOUT THE WRITTEN APPROVAL OF THE PROPRIETORS				
	DRAWN	Sanket S. D.	ALL DIMENSIONS ARE IN mm		DRG. NOT TO BE SCALED
	CHECKED	Mhetre T. R.	UNCLASSIFIED IF NOT MENTIONED		ALL SHARP EDGES TO BE ROUNDED OFF
	PASSED		SCALE	1:1	PERTAINS TO -
	APPROVED		DATE	18/08/16	
	TITLE				CIRT.DRG.NO.
Shaft 1 (FOR S.D./SATR)				CIRT/SDL/SATR/012	

CIRT/SDL/SATR/013

ALL DIM. ARE IN mm

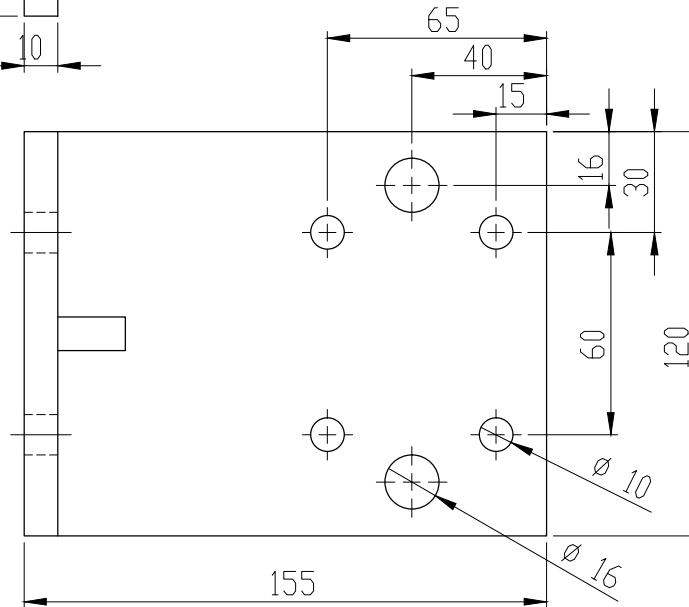
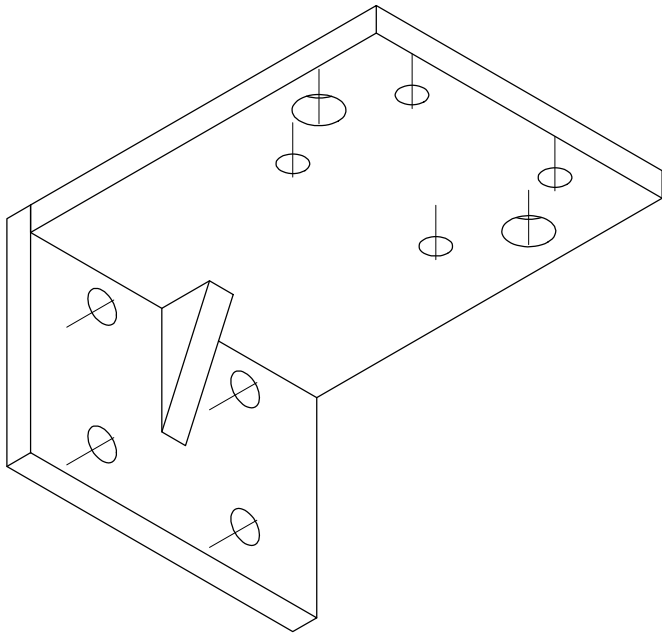
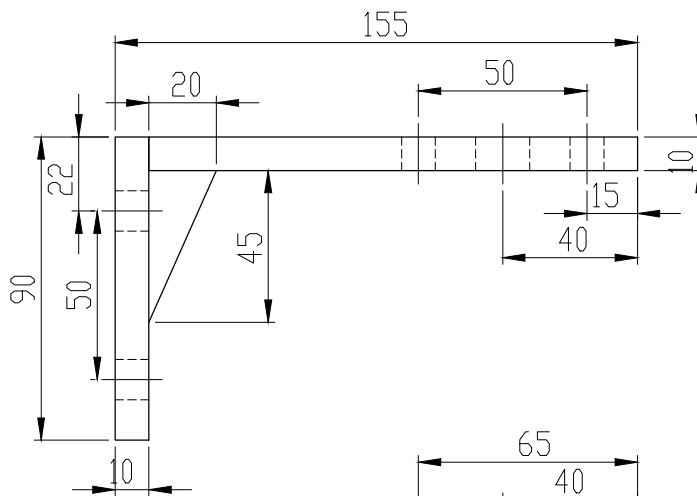
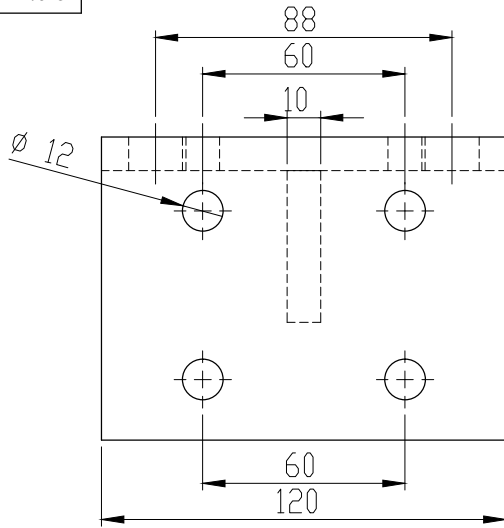

En-8		DETAILS		SIGN & DATE
S.NO.	MATERIAL	QTY	WT.(Kg)	REVISION No.00
Central Institute Of Road Transport				
THIS DRAWING IS SOLE PROPERTY OF CIRT. IT SHOULD NOT BE COPIED OR COMMUNICATED TO ANY PERSON WITHOUT THE WRITTEN APPROVAL OF THE PROPRIETORS				
DRAWN	Sanket S. D.	ALL DIMENSIONS ARE IN mm		DRG. NOT TO BE SCALED
CHECKED	Mhetre T. R.	UNCLASSIFIED IF NOT MENTIONED		ALL SHARP EDGES TO BE ROUNDED OFF
PASSED		SCALE	1:1	PERTAINS TO -
APPROVED		DATE	18/08/16	
TITLE				CIRT.DRG.NO.
Connecting Elbow (FOR S.D./SATR)				CIRT/SDL/SATR/013

TOLERANCE UNLESS OTHERWISE SPECIFIED TO BE AS PER IS: 2013

CIRT/SDL/SATR/014

ALL DIM. ARE IN mm

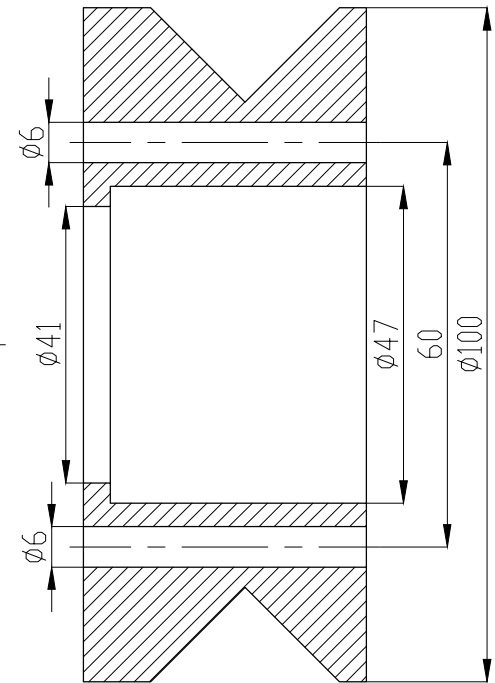
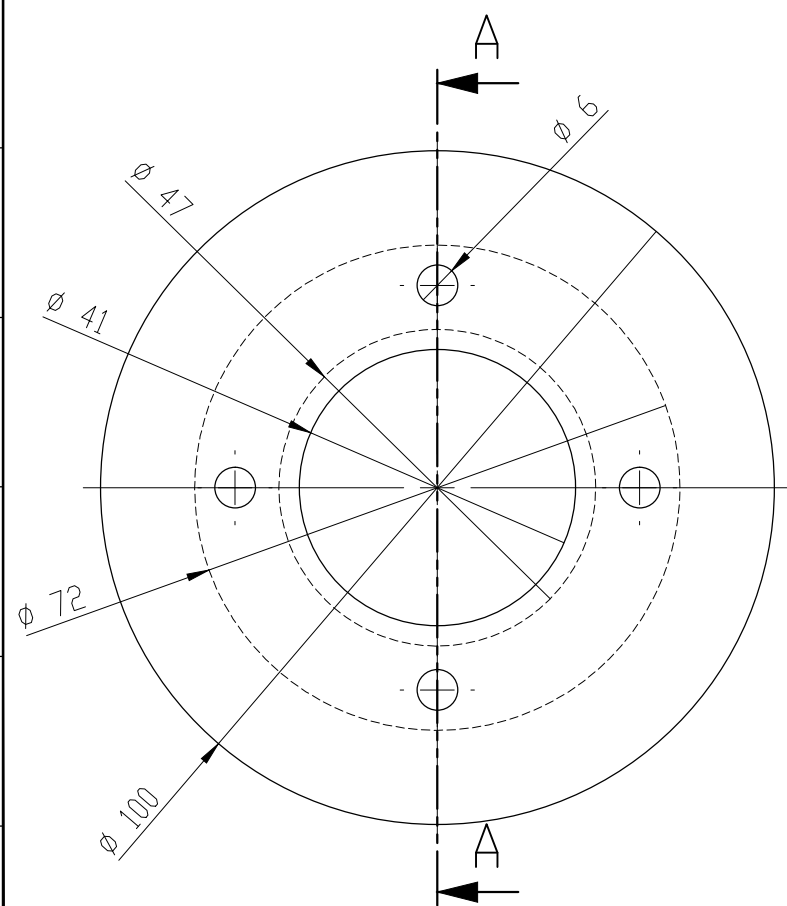
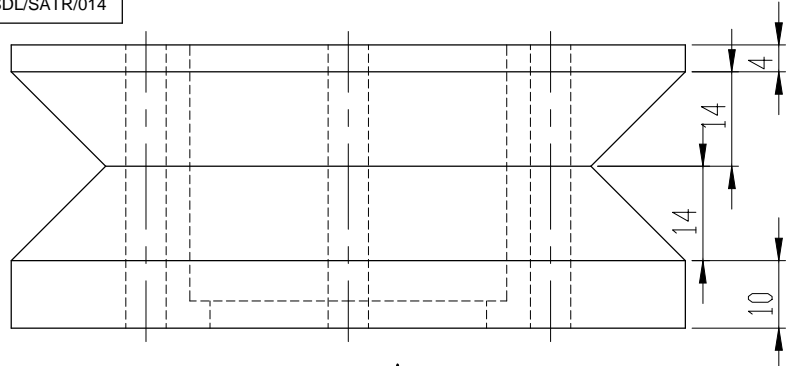

SECTION A-A

En-8				DETAILS	SIGN & DATE
S.NO.	MATERIAL	QTY	WT.(Kg)	REVISION No.00	
Central Institute Of Road Transport					
THIS DRAWING IS SOLE PROPERTY OF CIRT. IT SHOULD NOT BE COPIED OR COMMUNICATED TO ANY PERSON WITHOUT THE WRITTEN APPROVAL OF THE PROPRIETORS					
DRAWN	Sanket S. D.	ALL DIMENSIONS ARE IN mm		DRG. NOT TO BE SCALED	
CHECKED	Mhetre T. R.	UNCLASSIFIED IF NOT MENTIONED		ALL SHARP EDGES TO BE ROUNDED OFF	
PASSED		SCALE	1:1	PERTAINS TO -	
APPROVED		DATE	18/08/16		
TITLE				CIRT.DRG.NO.	
Rope roller Hub (FOR S.D.L/SATR)				CIRT/SDL/SATR/014	

TOLERANCE UNLESS OTHERWISE SPECIFIED TO BE AS PER IS: 2875-1989

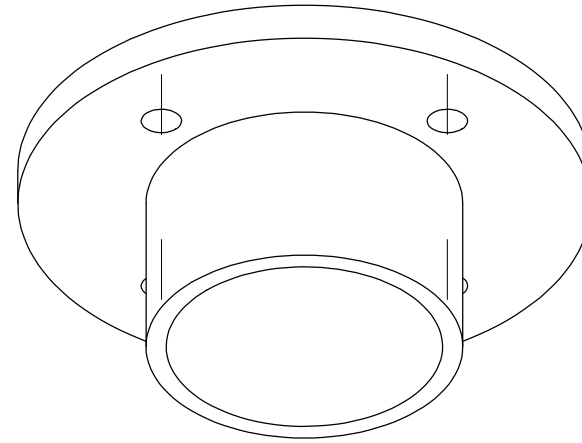
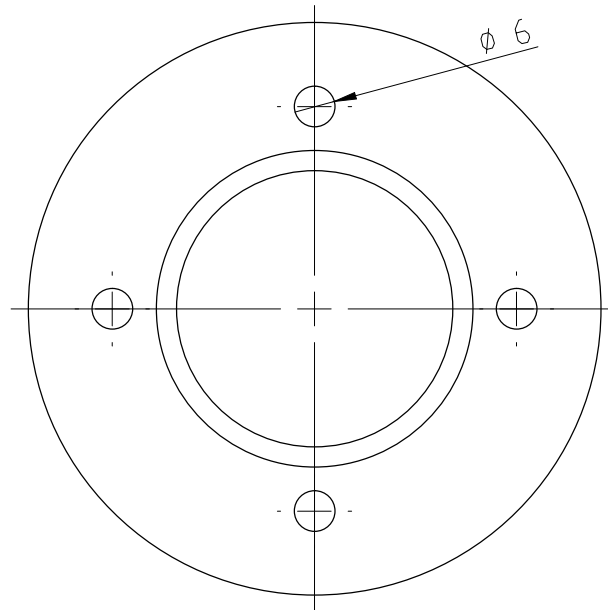
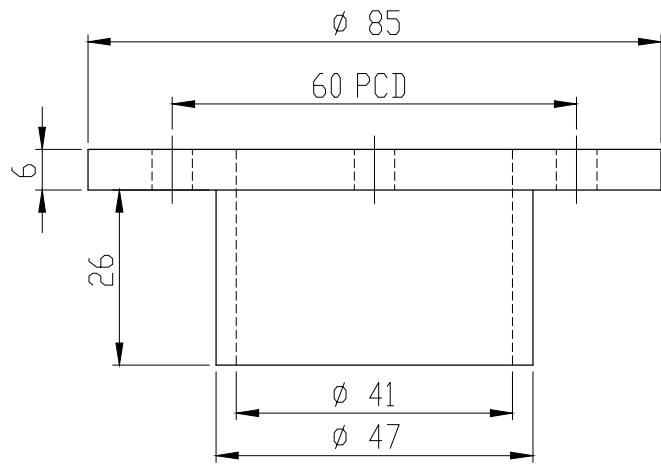

En-8		DETAILS		SIGN & DATE
S.NO.	MATERIAL	QTY	WT.(Kg)	REVISION No.00
Central Institute Of Road Transport THIS DRAWING IS SOLE PROPERTY OF CIRT. IT SHOULD NOT BE COPIED OR COMMUNICATED TO ANY PERSON WITHOUT THE WRITTEN APPROVAL OF THE PROPRIETORS				
DRAWN	Sanket S. D.	ALL DIMENSIONS ARE IN mm		DRG. NOT TO BE SCALED
CHECKED	Mhetre T. R.	UNCLASSIFIED IF NOT MENTIONED	ALL SHARP EDGES TO BE ROUNDED OFF	
PASSED		SCALE	PERTAINS TO -	
APPROVED		DATE	18/08/16	
TITLE				CIRT.DRG.NO.
Rope Roller cover (FOR S.D.L/SATR)				CIRT/SDL/SATR/015

CIRT/SDL/SATR/016

ALL DIM. ARE IN mm

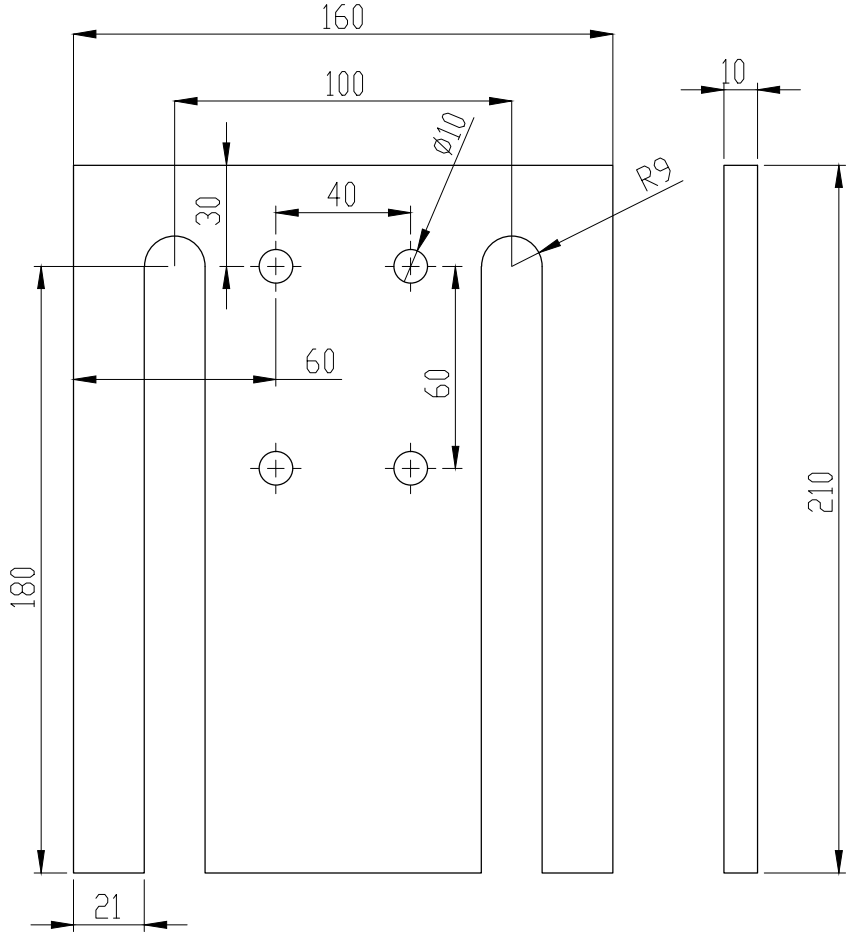

En-8		DETAILS		SIGN & DATE
S.NO.	MATERIAL	QTY	WT.(Kg)	REVISION No.00
Central Institute Of Road Transport THIS DRAWING IS SOLE PROPERTY OF CIRT. IT SHOULD NOT BE COPIED OR COMMUNICATED TO ANY PERSON WITHOUT THE WRITTEN APPROVAL OF THE PROPRIETORS				
DRAWN	Sanket S. D.	ALL DIMENSIONS ARE IN mm		DRG. NOT TO BE SCALED
CHECKED	Mhetre T. R.	UNCLASSIFIED IF NOT MENTIONED	ALL SHARP EDGES TO BE ROUNDED OFF	
PASSED		SCALE	1:1	PERTAINS TO -
APPROVED		DATE	18/08/16	
TITLE			CIRT.DRG.NO.	
Pulley Clamp (FOR S.D./SATR)			CIRT/SDL/SATR/016	

TOLERANCE UNLESS OTHERWISE SPECIFIED TO BE AS PER IS: 2013

CIRT/SDL/SATR/017

ALL DIM. ARE IN mm

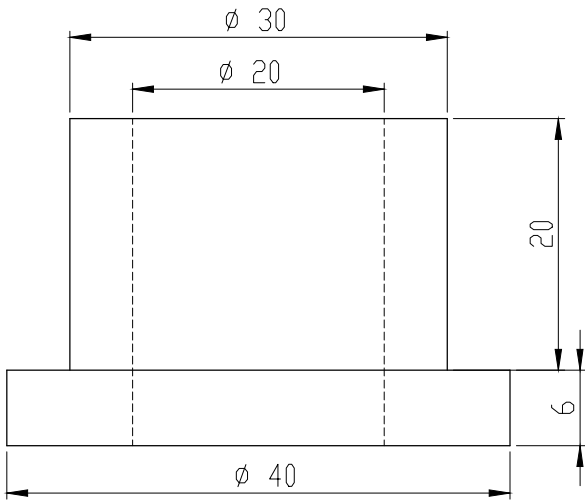
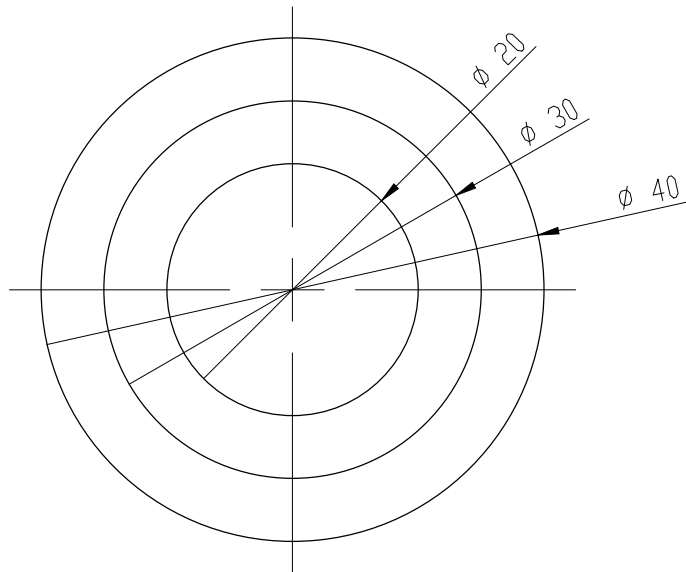

S.NO.		MATERIAL		QTY	WT.(Kg)	DETAILS	SIGN & DATE
REVISION No.00		Central Institute Of Road Transport					
THIS DRAWING IS SOLE PROPERTY OF CIRT. IT SHOULD NOT BE COPIED OR COMMUNICATED TO ANY PERSON WITHOUT THE WRITTEN APPROVAL OF THE PROPRIETORS							
DRAWN	Sanket S. D.	ALL DIMENSIONS ARE IN mm			DRG. NOT TO BE SCALED		
CHECKED	Mhetre T.R.	UNCLASSIFIED IF NOT MENTIONED			ALL SHARP EDGES TO BE ROUNDED OFF		
PASSED		SCALE	1:1	PERTAINS TO -			
APPROVED		DATE	18/05/16				
TITLE						CIRT.DRG.NO.	
20mm Bush						CIRT/SDL/SATR/017	
(FOR S.D.L / SATR)							

TOLERANCE UNLESS OTHERWISE SPECIFIED TO BE AS PER IS: 2875

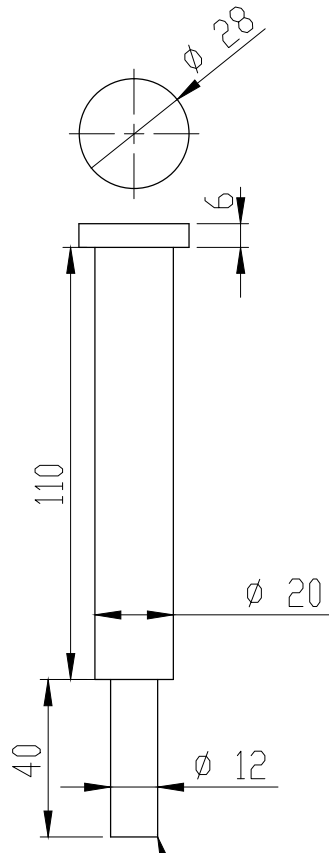

M12 Threading

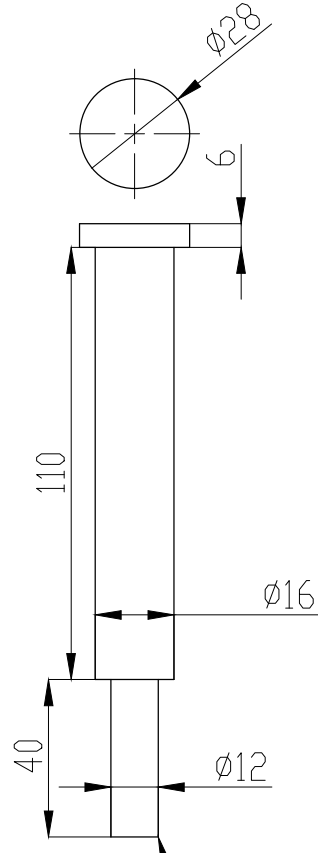

M12 Threading

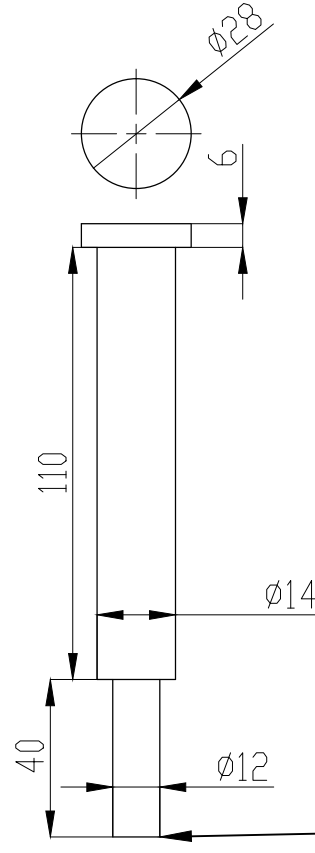

M12 Threading

TOLERANCE UNLESS OTHERWISE SPECIFIED TO BE IN mm	S.NO.		En-8		DETAILS		SIGN & DATE	
	MATERIAL		QTY		WT.(Kg)		REVISION No. 00	
	Central Institute Of Road Transport							
	THIS DRAWING IS SOLE PROPERTY OF CIRT. IT SHOULD NOT BE COPIED OR COMMUNICATED TO ANY PERSON WITHOUT THE WRITTEN APPROVAL OF THE PROPRIETORS							
	DRAWN	Sanket S. D.	ALL DIMENSIONS ARE IN mm			DRG. NOT TO BE SCALED		
CHECKED	Mhetre T. R.	UNCLASSIFIED IF NOT MENTIONED			ALL SHARP EDGES TO BE ROUNDED OFF			
PASSED		SCALE	1:1		PERTAINS TO -			
APPROVED		DATE	18/05/16					
TITLE		20 MM PIN (FOR S.D./ SATR)				CIRT.DRG.NO.		CIRT/SDL/SATR/018

CIRT/SDL/SATR/019

ALL DIM. ARE IN mm

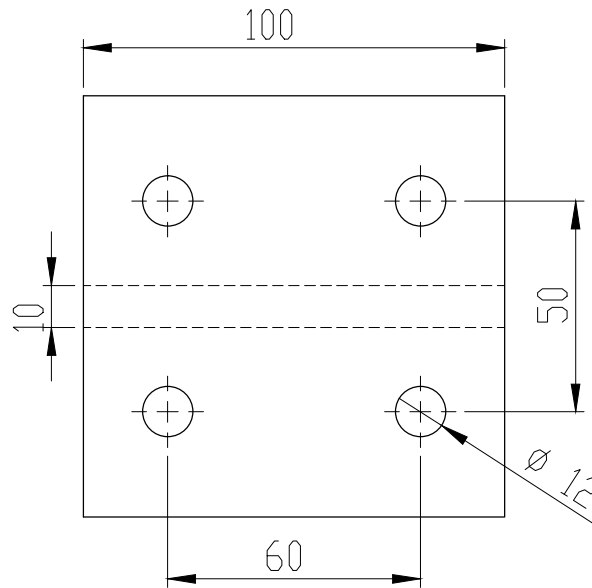
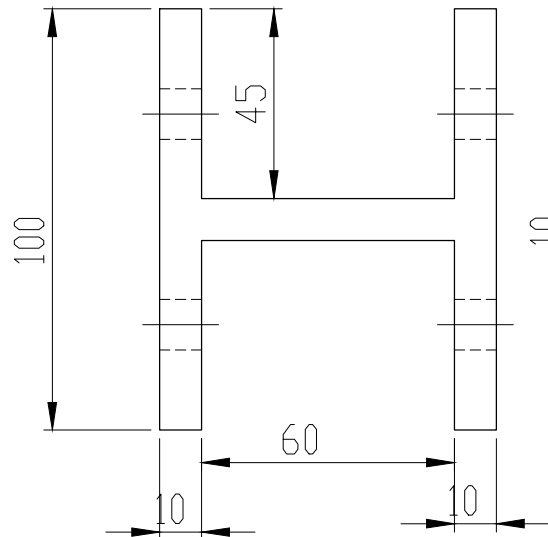
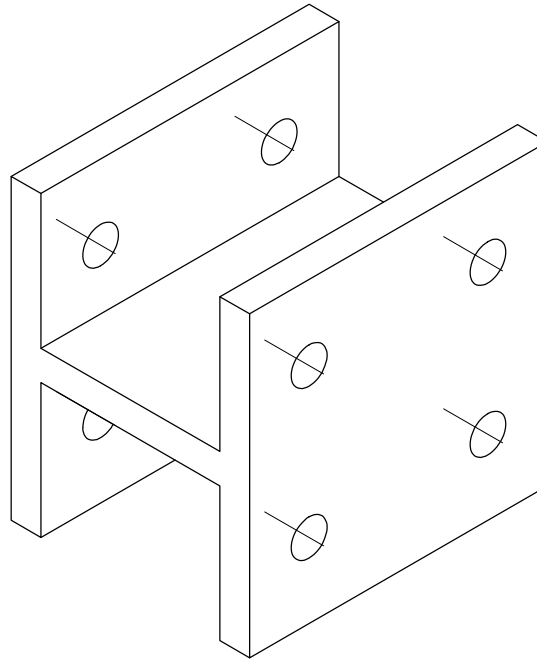
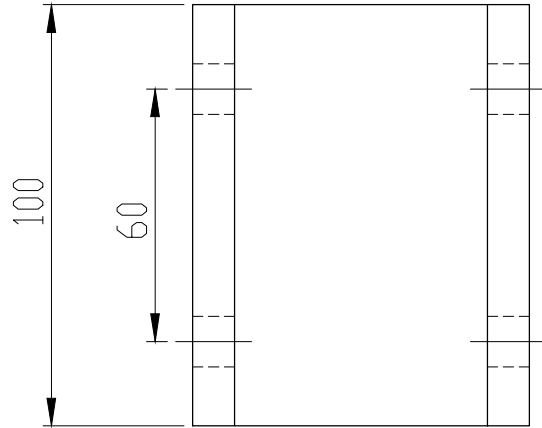

En-8				DETAILS	SIGN & DATE
S.NO.	MATERIAL	QTY	WT.(Kg)	REVISION No. 00	
Central Institute Of Road Transport THIS DRAWING IS SOLE PROPERTY OF CIRT. IT SHOULD NOT BE COPIED OR COMMUNICATED TO ANY PERSON WITHOUT THE WRITTEN APPROVAL OF THE PROPRIETORS					
DRAWN	Sanket S. D.	ALL DIMENSIONS ARE IN mm		DRG. NOT TO BE SCALED	
CHECKED	Mhetre T. R.	UNCLASSIFIED IF NOT MENTIONED		ALL SHARP EDGES TO BE ROUNDED OFF	
PASSED		SCALE	1:1	PERTAINS TO -	
APPROVED		DATE	18/08/16		
TITLE				CIRT.DRG.NO.	
WIRE CLAMP (FOR S.D.L/SATR)				CIRT/SDL/SATR/019	

TOLERANCE UNLESS OTHERWISE SPECIFIED TO BE AS PER IS: 2875

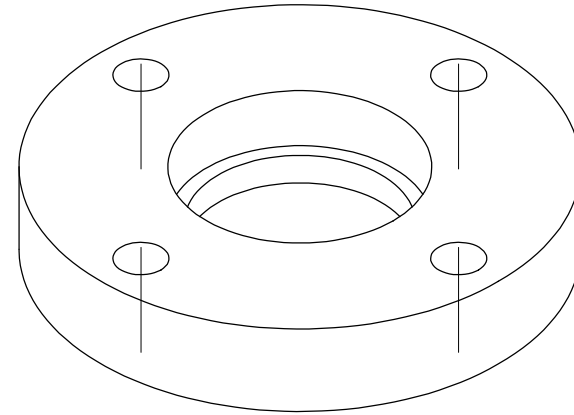
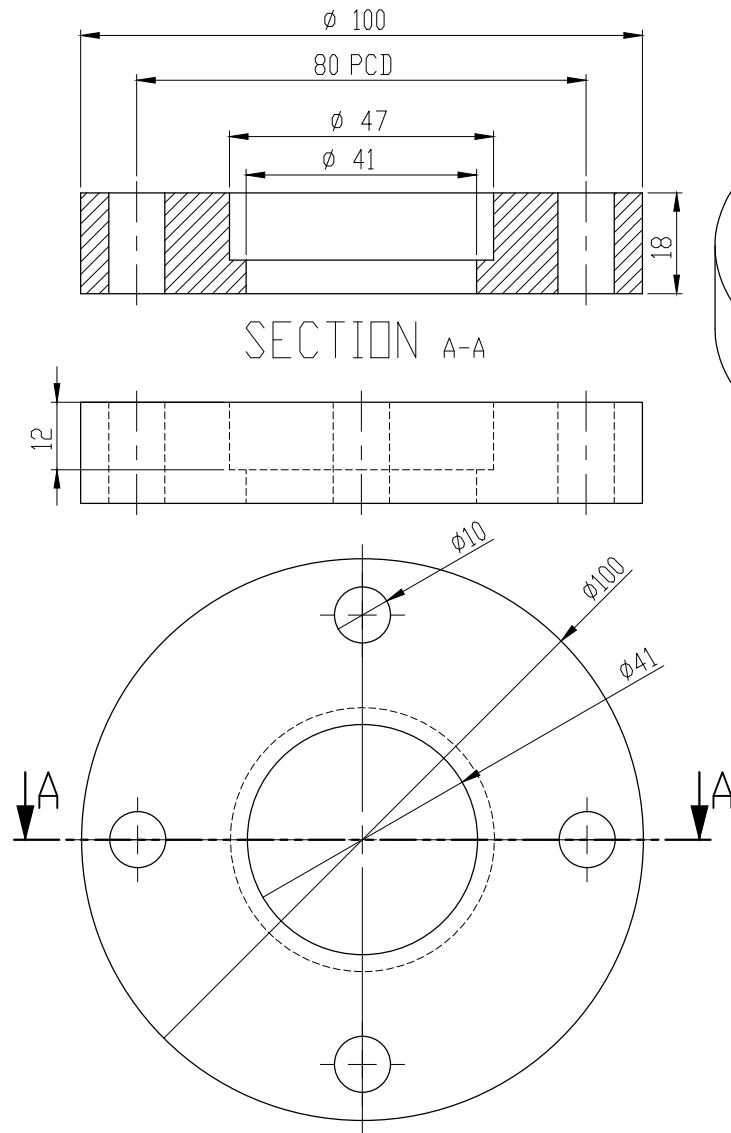

En-8		DETAILS		SIGN & DATE
S.NO.	MATERIAL	QTY	WT.(Kg)	REVISION No. 00
All Edges Filled Rounded. No Sharp corners THIS DRAWING IS SOLE PROPERTY OF CIRT. IT SHOULD NOT BE COPIED OR COMMUNICATED TO ANY PERSON WITHOUT THE WRITTEN APPROVAL OF THE PROPRIETORS				
DRAWN	Sanket S. D.	ALL DIMENSIONS ARE IN mm	DRG. NOT TO BE SCALED	
CHECKED	Mhetre T. R.	UNCLASSIFIED IF NOT MENTIONED	ALL SHARP EDGES TO BE ROUNDED OFF	
PASSED		SCALE 1:1	PERTAINS TO -	
APPROVED		DATE 18/08/16		
TITLE			CIRT.DRG.NO.	
BEARING SEAT (FOR S.D./SATR)			CIRT/SDL/SATR/020	

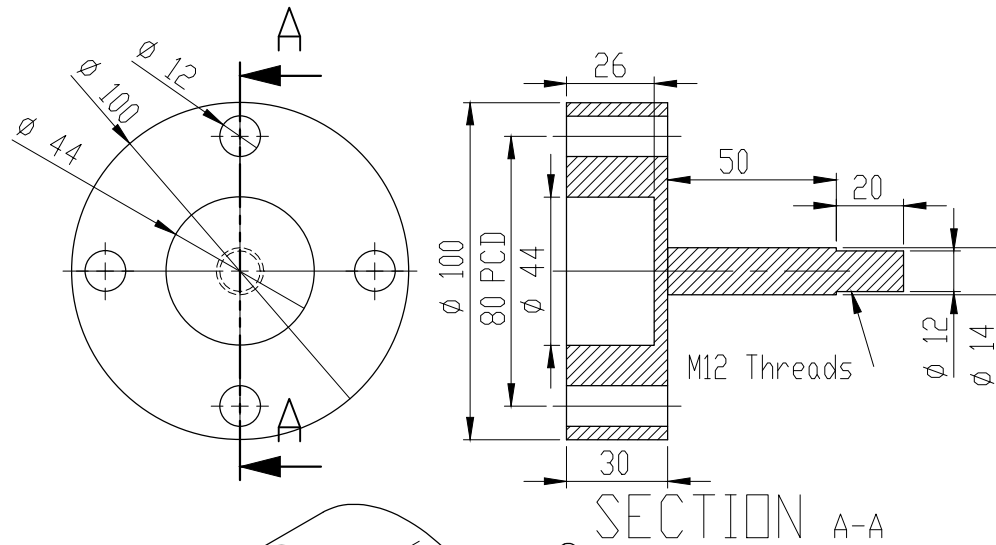

SECTION A-A

En-8		DETAILS		SIGN & DATE
S.NO.	MATERIAL	QTY	WT.(Kg)	REVISION No.00
Central Institute Of Road Transport				
THIS DRAWING IS SOLE PROPERTY OF CIRT. IT SHOULD NOT BE COPIED OR COMMUNICATED TO ANY PERSON WITHOUT THE WRITTEN APPROVAL OF THE PROPRIETORS				
DRAWN	Sanket S. D.	ALL DIMENSIONS ARE IN mm	DRG. NOT TO BE SCALED	
CHECKED	Mhetre T. R.	UNCLASSIFIED IF NOT MENTIONED	ALL SHARP EDGES TO BE ROUNDED OFF	
PASSED		SCALE 1:1	PERTAINS TO -	
APPROVED		DATE 18/08/16		
TITLE			CIRT.DRG.NO.	
BEARING HUB (FOR S.D./SATR)			CIRT/SDL/SATR/021	

TOLERANCE UNLESS OTHERWISE SPECIFIED TO BE AS PER IS: 2875-1987

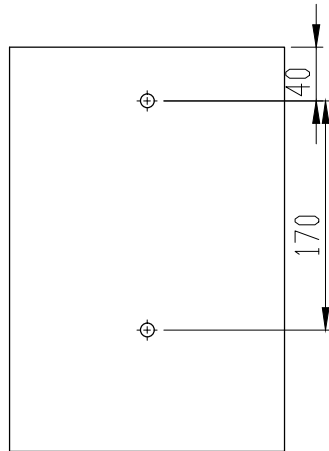
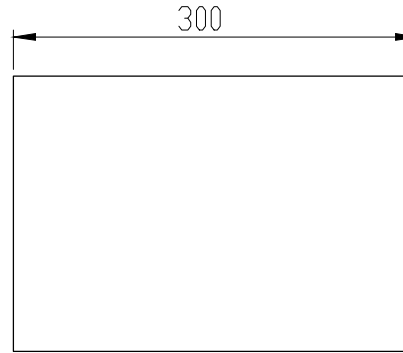
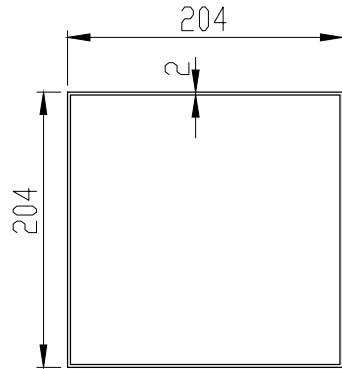

Only for reference,
actual dimesions other
than height, width of
bath may vary as per
available matching
componnents for
cooling water
circulation

En-8		DETAILS		SIGN & DATE
S.NO.	MATERIAL	QTY	WT.(Kg)	REVISION No.00
Central Institute Of Road Transport				
THIS DRAWING IS SOLE PROPERTY OF CIRT. IT SHOULD NOT BE COPIED OR COMMUNICATED TO ANY PERSON WITHOUT THE WRITTEN APPROVAL OF THE PROPRIETORS				
DRAWN	Sanket S. D.	ALL DIMENSIONS ARE IN mm	DRG. NOT TO BE SCALED	
CHECKED	Mhetre T. R.	UNCLASSIFIED IF NOT MENTIONED	ALL SHARP EDGES TO BE ROUNDED OFF	
PASSED		SCALE 1:1	PERTAINS TO -	
APPROVED		DATE 18/08/16		
TITLE			CIRT.DRG.NO.	
WATER TUB (FOR S.D.L/SATR)			CIRT/SDL/SATR/022	